

TECHNICAL DATA
TYPE: DIG-MAZ 50 Vacuum

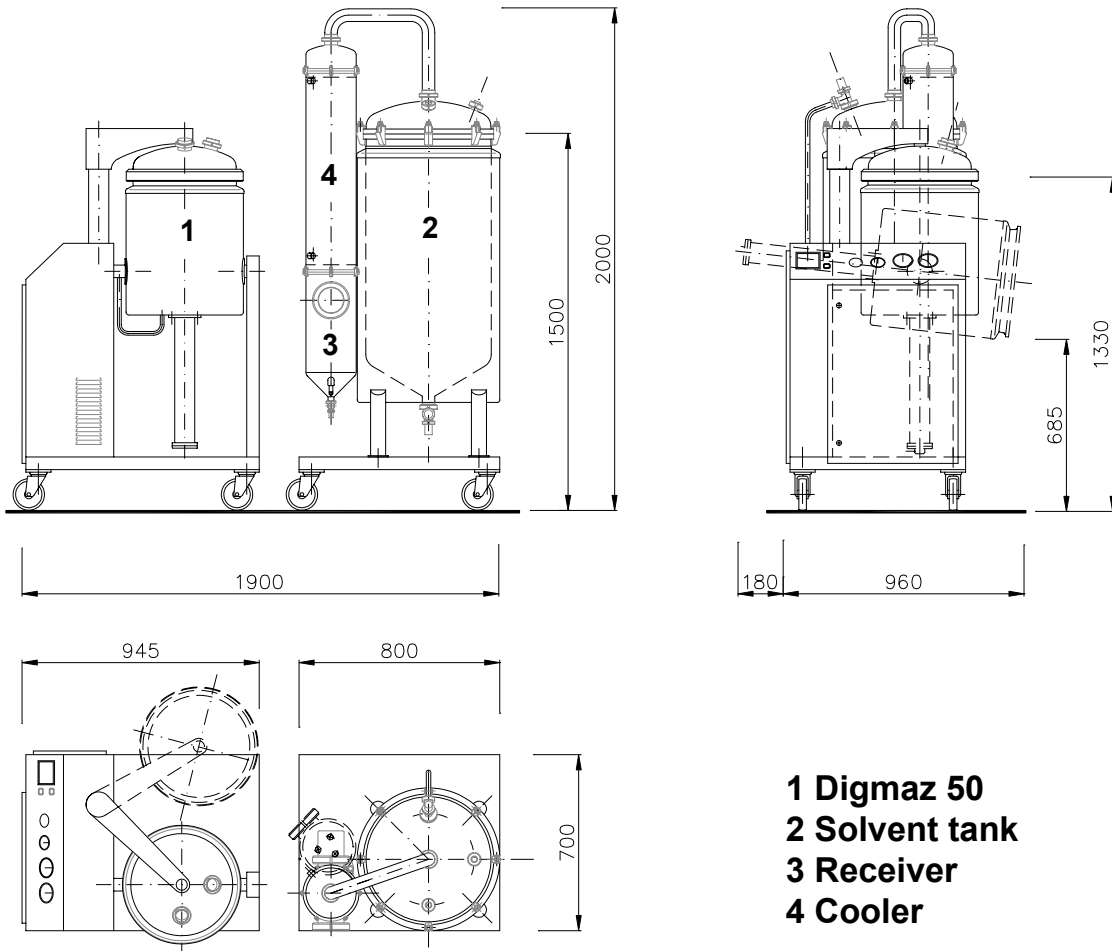

Type:	DIG-MAZ 50	
Extraction tank:	50 liters	Herbs volume
Solvent tank:	175 liters	
Heating:	40 kW	electrical
Refrigeration:	30 kW	electrical
Distillate:	50 liters / h	
Compressed air:	6 bar	4 m ³ / h
Power supply:	3x400 V / 50 Hz	
Power consumption:	60 kW	
Compressing pressure:	750 kg	pneumatic
Weight:	220 kg	